

upsaver[®] 3vo

Modular High Power UPS
for large data centres
Hot scalable up to 2.67 MW
Ultimate scalability and flexibility



BORRI[®]

Modular, scalable and adaptable high power UPS's for Enterprise Data Centres and IT business critical applications, designed for the changing demands of your Data Centre with the Lowest Total Cost of Ownership (TCO).



Applications

- Data centres
- Cloud
- Networking services
- Telecommunication equipment
- Critical cooling

Highlights

- 98.5% average efficiency (VFI 97%) and 4 high efficiency operating modes.
- Hot scalable 333 kW modules up to 2.67 MW in a single unit.
- Power parallel scalable up to 21 MW.
- Very small footprint and 572 kW/m² power density.
- System design flexibility.
- Total installation adaptability.
- VRLA, Li-Ion and Fly-Wheel compatible.
- Solutions for peak shaving.
- 10" colour touch screen display.



Reduced TCO

Reducing your Total Cost of Ownership (TCO) is our goal.

How UPSaver 3vo helps your CapEx:

- Pay as you grow thanks to hot scalability.
- Tailored to the room layout thanks to total design and installation flexibility.
- Minimal spare parts thanks to sub-modularity.

How UPSaver 3vo helps your OpEx:

- Quick upgrade and maintenance thanks to hot scalability and serviceability.
- Adapts to load requirement thanks to automatic power control.
- Always delivering maximum efficiency thanks to 4 high efficiency operating modes.
- Higher efficiency also means less cooling thus reducing your CO₂ footprint.



98.5% Average Efficiency

Borri UPSaver 3vo delivering unsurpassed system efficiency for maximum availability and cost saving. Adaptive capability and automatic power control to maximize the system efficiency while maintaining full system reliability thanks to Load Based Shutdown algorithm.

3-L patented Green Conversion technology

- Latest generation IGBT.
- UPS life extension.
- Battery life extension.

Revolutionary Current Parallel of Modules

- No circulating currents.
- No system efficiency reduction.
- Stable high power parallel system.
- No stress on battery and power components.
- Distributed redundancy is easily achieved.

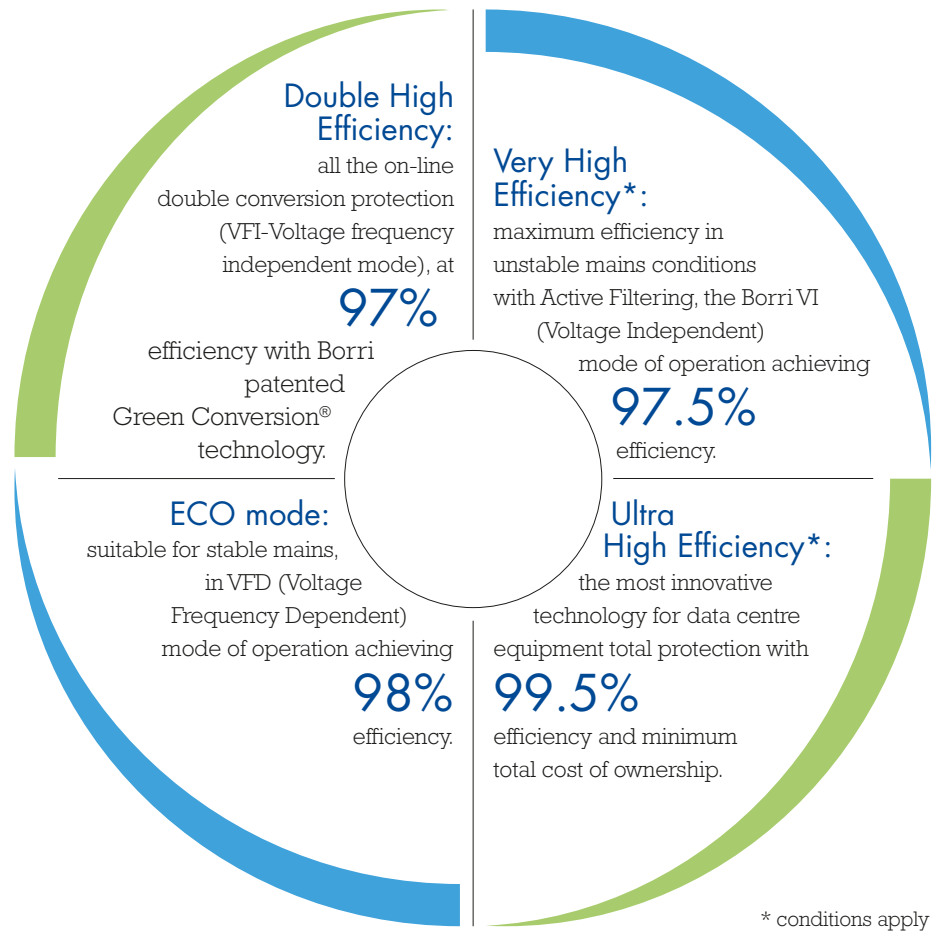

4 dynamic operation modes

- High efficiency double conversion VFI.
- Enhanced Active Filtering VI.
- Energy saving ECO mode VFD.
- Ultra High Efficiency mode VFD.

97% VFI efficiency at any load

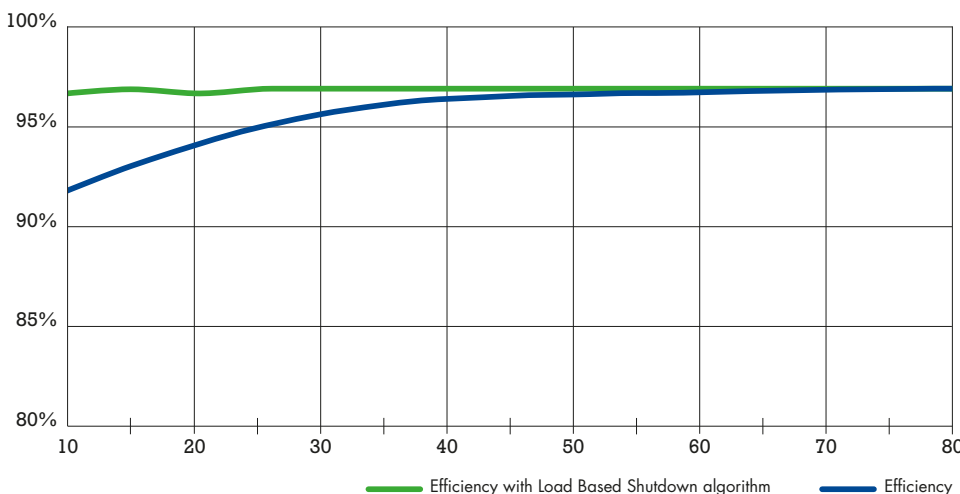

Load Based Shutdown algorithm optimizes the number of active modules to maximize system efficiency. This enables the UPS to adapt to load requirement, whilst keeping highest VFI protection.

- Energy saving at data centre typical operation.
 - Extended service life.
 - Enhanced module performance.
- Operational and TCO peace of mind.

3D Scalability

Hot VFI scalability up to 2.67 MW in a single unit, up to 21 MW in a parallel system and synchronized dual feed systems.

Flexible power upgrade

- X- Hot Swap Module Scalability to 2.67 MW.
- Y- Parallel Power Scalability up to 21 MW.
- Z- Availability Scalability for distributed redundancy.

Designed for versatility

UPSaver 3vo is an extremely versatile system, allowing for any maintenance or power resizing to be carried out while units are online. Top or bottom entry for cables or busbar and adaptive terminal boards ensure robust design in any data centre electrical infrastructure.

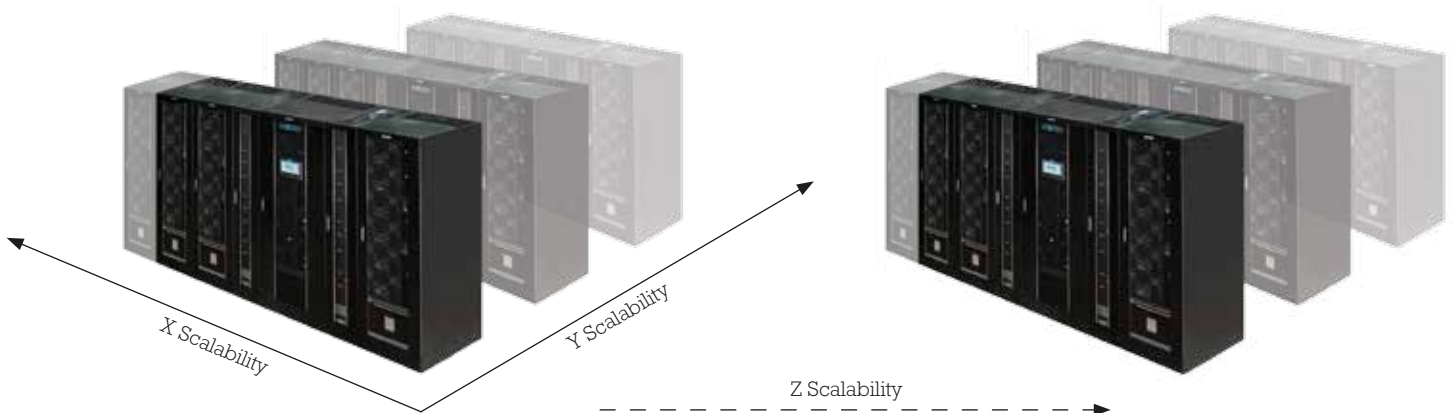

Minimised Service Time

Hot VFI swappable in minutes for lowest MTTR

Sub-modules can be individually extracted for service purposes while the UPS is protecting your critical load in VFI mode.

Replacing all power components and no firmware to update

All serviceable components are fitted in sub-modules and no firmware to update upon replacement, ensuring Periodical Preventive Maintenance in no time.

Minimal spare parts: one fits all

Same sub-module up to 2.67 MW allowing you to secure the whole range of units with minimal spare part set.



Distributed Static Bypass
Distributed Battery
for unparallelled modularity

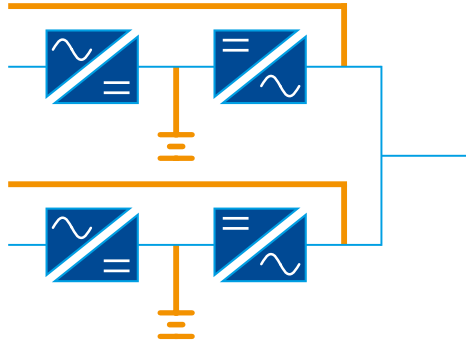

Each 333 kW module is equipped with a static bypass switch and a dedicated battery bank.
The highest system flexibility for maximum adaptive capability to variable IT space.

Distributed Static Bypass
Central Battery
for minimum floorspace

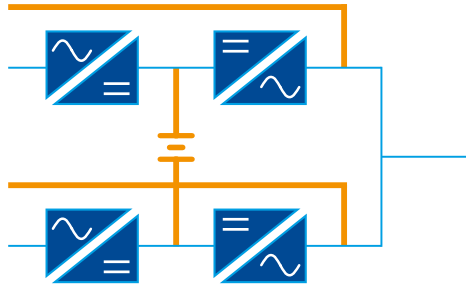

Each 333 kW module is equipped with a static bypass switch.
A single battery bank is connected to the UPS. DC isolation with string separators can be used to ensure live maintainability.
The most cost effective and space saving modular solution.

Central Static Bypass
Distributed Battery
for enhanced short circuit protection

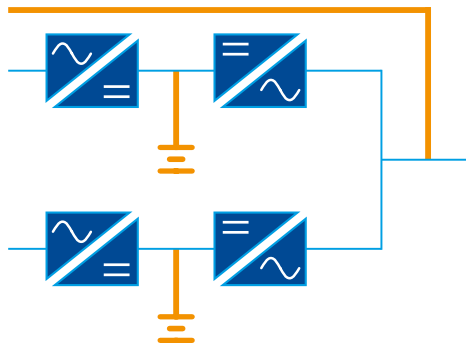

A central static bypass switch is fitted, sized for the whole UPS power.
Each 333 kW module is equipped with a dedicated battery bank.
This ensures high fault current which might be needed when the UPS is installed next to the MV/LV switchboard.

Central Static Bypass
Central Battery
minimum MTTR maximum selectivity

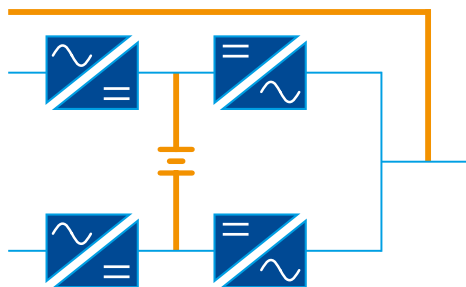

A central static bypass switch is fitted, sized for the whole UPS power and a single battery bank is connected to the UPS.
DC isolation with string separators can be used to ensure live maintainability.
The robustness of a standalone UPS in a modular layout, for minimum MTTR and maximum selectivity performance.

Optimised Footprint

Extreme layout flexibility allows you to free space up for other equipment or overcome room constraints like pillars, walls or other devices. UPSaver 3vo is designed around your new or existing data centre.

Careless Positioning

- Flexible layout.
- No rear or side access.
- Top or Bottom Cable Entry.
- 572 kW/m² power density.

Constraint-free layout

333 kW modules are connected to the I/O unit by internal flexible connections, allowing constraint-overcoming positioning like packed layout, L-shape layout, offset layout and more.

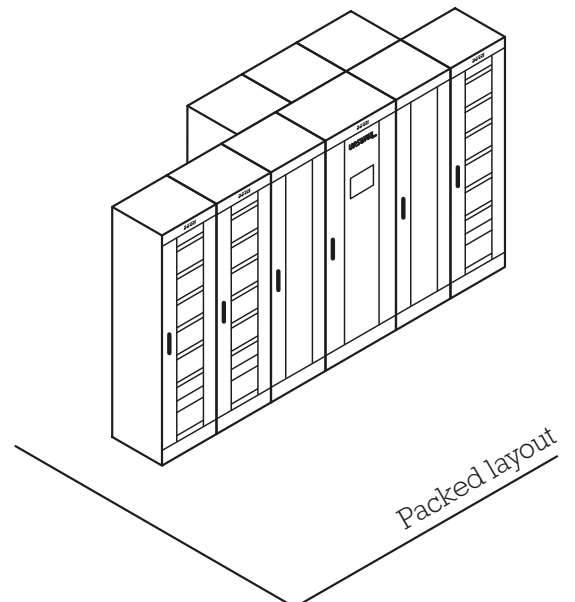
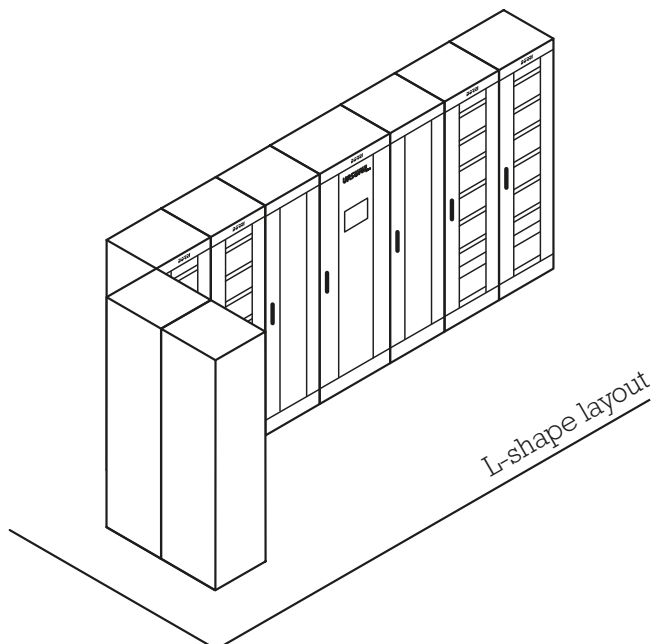
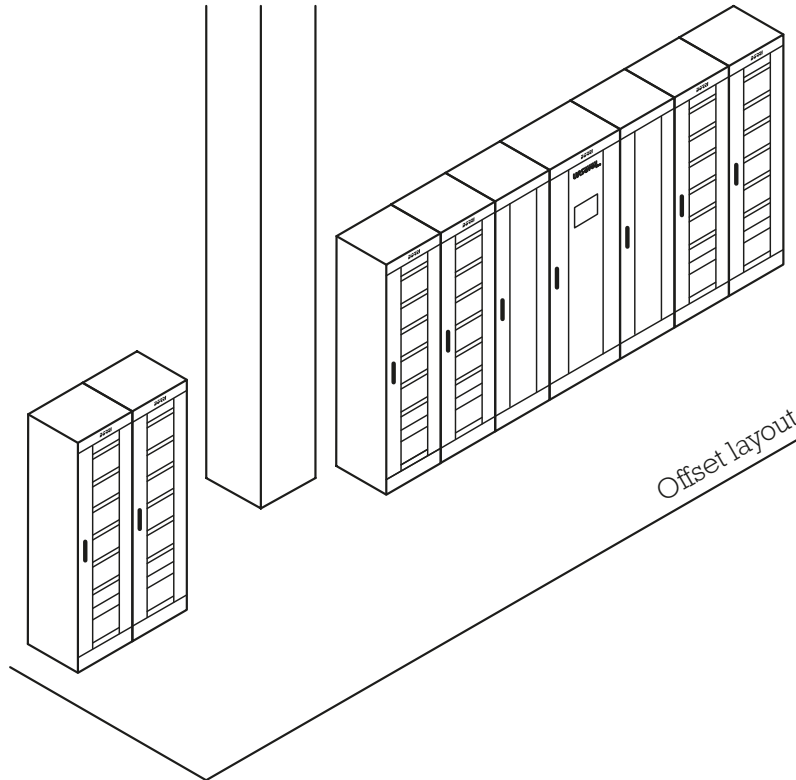

UPSAVER 3vo technical data

Rating (kVA)	670	1000	1340	1670	2000	2340	2670
N nominal power (kW)	670	1000	1340	1670	2000	2340	2670
No. of modules	2	3	4	5	6	7	8
UPS dimensions WxDxH (mm)*	2450x970x2100	3050x970x2100	4100x970x2100	4700x970x2100	5700x970x2100	(***)	(***)
UPS weight (kg)*	1800	2540	3170	3900	4700	(***)	(***)
Battery configuration	External 360 to 372 cells, VRLA (other options)						

Input

Connection type	Hardwired 4w (rectifier), 4w (bypass)
Nominal voltage	400 Vac 3-phase with neutral (rectifier), 380/400/415 Vac 3-phase with neutral (bypass)
Voltage tolerance	-20%, +15% (rectifier); $\pm 10\%$ (bypass)
Frequency and range	50/60 Hz, 45 to 65 Hz
Power factor	0.99
Current distortion (THDi)	<3%

Output

Connection type	Hardwired 4w
Nominal voltage	380/400/415 Vac 3-phase with neutral
Frequency	50/60 Hz
Voltage regulation (VFI)	Static: $\pm 1\%$; dynamic: IEC/EN 62040-3 Class 1
Power factor	Any power factor (leading or lagging) up to 1, without power derating
Overload capability	Inverter: 125% for 10 min, 150% for 1 min; bypass: 150% continuous, 1000% for 1 cycle
AC/AC efficiency**	Up to 99.5%
Classification as per IEC/EN 62040-3	VFI-SS-111

Connectivity and function extensions

Front panel	10" colour touch screen display, 1024x600 pixels
Remote communication	Included: serial RS232 and USB; input terminal block (remote emergency power off, battery circuit breaker aux. cont., external maintenance bypass circuit breaker aux. cont., diesel mode aux. cont., external output circuit breaker aux. cont., remote transfer to bypass mode); SPDT contact relay board; ModBus-RTU (RS485); Optional: ModBus-TCP/IP (Ethernet); ModBus-RTU to PROFIBUS DP adapter
Optional features	Isolation transformer; custom battery cabinets; wall-mounted battery fuse switch box; battery thermal probe; parallel kit; load-sync for single UPS and load-sync box (2 UPS systems); other options on request

System

Protection degree	IP 20
Colour	RAL 9005
Installation layout	Wall, back to back and side by side installation allowed
Accessibility	Front and top access, bottom and top cable entry
Parallel configuration	Up to 8 UPS, for a total of 21 MW

* referred to distributed battery, distributed static switch, bottom cable entry. For other configurations contact our sales team ** according to IEC/EN 62040-3 *** contact our sales team

Other features

Environmental

Operating temperature	0°C to +40°C
Storage temperature	-10°C to +70°C
Altitude (AMSL)	< 1000 m without power reduction, > 1000 m with reduction of 0.5% per 100 m
Audible noise at 1m (dBA)	<50 (UHE)

Standards and certifications

Quality assurance, environment, health and safety	ISO 9001:2008, ISO 14001:2004, BS OHSAS 18001:2007
Safety	IEC/EN 62040-1
EMC	IEC/EN 62040-2
Environmental aspects	IEC/EN 62040-4
Test and performance	IEC/EN 62040-3
Protection degree	IEC 60529
Marking	CE

Borri Headquarters and Factory**Borri S.p.A**

Via 8 Marzo, 2
52011 Bibbiena (AR)
Italy
Tel. +39 0575 5351
Fax +39 0575 561811
info@borri.it

Borri Subsidiaries and Service Centres**Asia Pacific****Borri Asia Pacific Engineering Sdn. Bhd.**

No.13, Jalan Serendah 26/41,
Sekitar 26, Seksyen 26,
40400 Shah Alam, Selangor
Malaysia
Tel. +60 3 5191 9098
Fax +60 3 5103 8728
sales@borri-asia.com

Canada**Borri Power Systems North America Inc.**

205 - 3689 E 1st Ave.
Vancouver, BC V5M 1C2
Canada
Tel. +1 604 439 3054
Fax +1 604 439 3053
info@borripower.com

Germany**Borri Power Germany GmbH**

Gewerbestraße 10
26789 Leer
Germany
Tel. +49 491 99 75 61 83
Fax +49 491 99 75 61 84
info@borri.de
service@borri.de

India**Borri Power India Pvt. Ltd.**

Plot No. 69, Ground Floor
Nagarjuna Hills, Panjagutta
Hyderabad, 500 082
India
Tel. +91 40 2335 4095
info@mea.borripower.com

Middle East and Africa**Borri Power Middle East FZCO**

1-151, Techno Hub
PO Box: 342036
Dubai Silicon Oasis, Dubai UAE
Tel. +971 4 3200528
Fax +971 4 3200529
info@mea.borripower.com

USA**Borri Power (US) Inc.**

9000 Clay Road, Suit 108
Houston, Texas, 77080
USA
Tel. +1 346 212 2686
Fax +1 346 980 8875
info@borripower.com

Who we are

Borri Group is a global provider of power electronics systems and solutions for harsh industrial and demanding commercial and ICT secure power requirements merging over eighty years of experience in developing, manufacturing and supplying uninterruptible power systems and solutions.

The Research and Development Team's expertise combines AC and DC power technologies spanning the worlds of both conventional and renewable energy, to provide innovative solutions for tomorrows problems.

The company is comprised of three business units: Industrial Power, Critical Power and Renewable Power, headquartered in Bibbiena, Italy. Borri's latest products, based on Green Conversion operation, guarantee the best PUE for green data centres: proof of the ongoing company commitment to innovation.

Thanks to its highly skilled custom engineers Borri controls in-house the entire process: from feed studies to design, production and after-sales service guaranteeing state-of-the-art solutions. Based in Italy with over 20,000 m² production area and a large high power test field, Borri can depend on its more than 80 years of experience and multidisciplinary research and development to serve our customers best.